

AUTOMATIC AIR AND GAS VENTS FOR LIQUID SYSTEMS AE32

DESCRIPTION

The AE32 carbon steel air eliminator removes air from cold, hot and superheated water systems and is also suitable for all liquids compatible with the construction, providing that their specific weight is no less than 0,75 kg/dm³.

This ball float type automatic air eliminator can be used in combination with other air elimination and separation systems or directly applied at high points in the piping

MAIN FEATURES

Corrosion resistant working parts.

Replaceable internal parts.

USE: Cold, hot and superheated water systems or other liquids compatible with the construction.

AVAILABLE MODELS:

AE32 – carbon steel.

SIZES:

1"; DN 25.

CONNECTIONS:

Female threaded ISO 7 Rp or NPT.
Flanged EN 1092-1 PN 40.
Flanged ASME B16.5 Class 150 or 300.
Special flanges upon request.

INSTALLATION:

Horizontal or vertical installation (on request).
It must be installed with the float lever in an horizontal plane, so that it rises and falls vertically. It should be installed at the points of the plant where the air tends to collect.
The drain should be piped to a safe position.
See IMI – Installation and maintenance instructions.

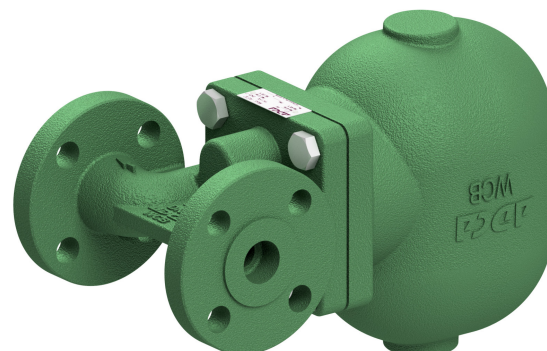

APPLICATION LIMITS	
Minimum liquid specific weight	0,75 kg/dm ³
Maximum working differential pressure	17 bar

CE MARKING – GROUP 2 (PED – European Directive)	
PN 40	Category
1" – DN 25	1 (CE marked)

BODY LIMITING CONDITIONS		
FLANGED PN 40/ CLASS 300 *	FLANGED CLASS 150 **	RELATED TEMP.
ALLOWABLE PRESSURES	ALLOWABLE PRESSURES	
37,1 bar	15,4 bar	100 °C
33,3 bar	13,8 bar	200 °C
30,4 bar	12,1 bar	250 °C
27,6 bar	10,2 bar	300 °C

PMO – Maximum operating pressure: 32 bar.

TMO – Maximum operating temperature: 200 °C.

* According to EN 1092-1:2018.

** According to EN 1759-1:2004.

Body limiting conditions PN 40 or below, depending on the type of connections adopted. Rating PN 40 for threaded, SW and BW versions.

FLOW RATE CAPACITY (NL/min)										
MODEL	SIZE	DIFFERENTIAL PRESSURE (bar)								
		0,5	1	2	4	6	8	10	13	17
AE32-17	1" – DN 25	75	120	240	420	535	720	870	1200	1380

Capacities shown refer to the capacity of air discharge at 15 °C, under atmospheric pressure.

If the temperature of the air differs from 15 °C, the discharge capacity can be corrected by multiplying it by: $\frac{288}{273 + T}$, where T is the actual temperature in °C.

It may be assumed that the temperature of the air is equal to the temperature of the water.

DIMENSIONS (mm)

SIZE	THREADED						PN 40			PN 40 *			CLASS 150			CLASS 150 *			CLASS 300			CLASS 300 *		
	A	B	C	D	E	WT. (kg)	F	G	WT. (kg)	F	B	WT. (kg)	F	G	WT. (kg)	F	B	WT. (kg)	F	G	WT. (kg)	F	B	WT. (kg)
1 – DN 25	120	195	80	190	110	9	160	248	11,3	230	195	12	160	248	11	230	195	11,2	160	248	11,3	230	195	12,8

* Alternative.

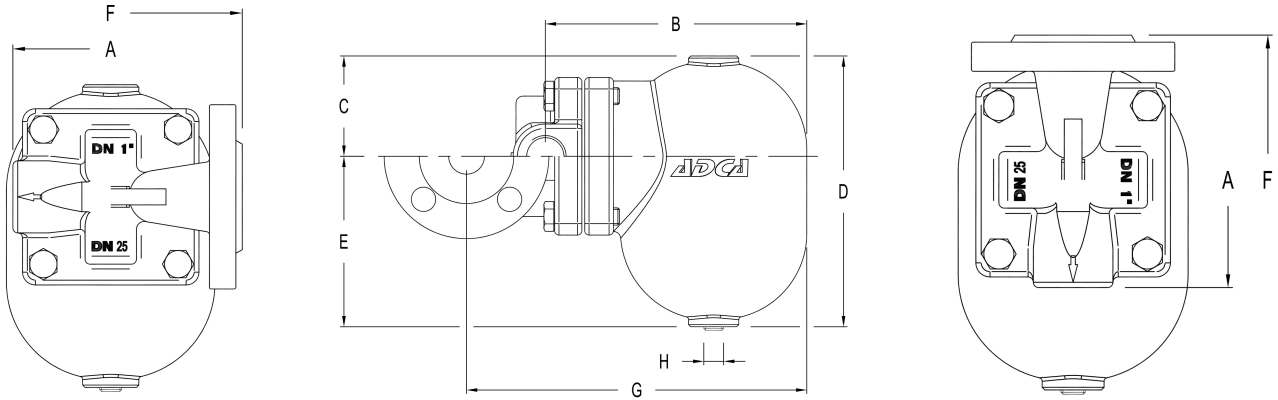

MATERIALS

POS. N°	DESIGNATION	MATERIAL
1	Body	GP240GH / 1.0619
2	Cover	GP240GH / 1.0619
3	* Gasket	Stainless steel / Graphite
4	* Seat	AISI 410 / 1.4006
5	* Valve	AISI 440C / 1.4125
6	* Lever	AISI 304 / 1.4301
7	* Float	AISI 304 / 1.4301
8A	** Compression fitting	Stainless steel or Steel Fe/Zn
9	Bolts	Steel 8.8

* Available spare parts. ** Optional, against extra price.

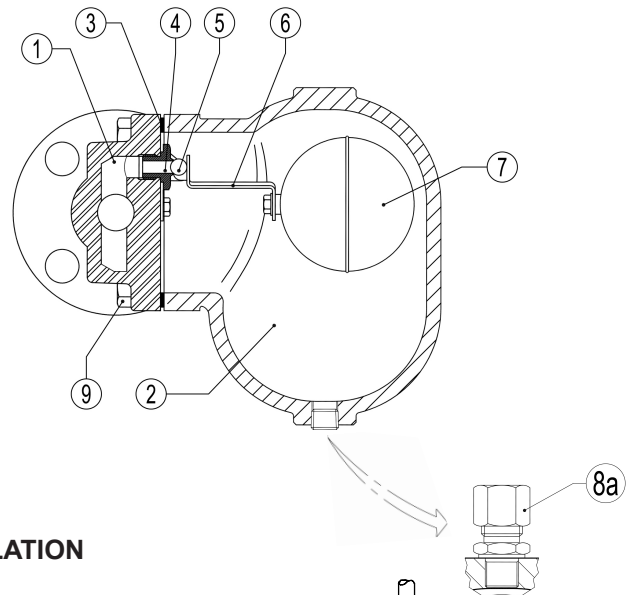

TYPICAL INSTALLATION

